

THE *General Radio* EXPERIMENTER

VOLUME XIV NO. 7

DECEMBER, 1939

ELECTRICAL MEASUREMENTS AND THEIR INDUSTRIAL APPLICATIONS

Also

IN THIS ISSUE

Page

HIGH QUALITY AUDIO
TRANSFORMERS . . . 6

NETWORK TESTING WITH SQUARE WAVES

● THE THEORY OF THE RESPONSE OF NETWORKS to transient impulses has been known and discussed for many years, and from time to time various individuals, particularly those familiar with operational calculus, have used square waves in testing networks. This test method has not been widely applied to communication circuits until quite recently* when its obvious applicability to television circuits has attracted attention to it. Its application to audio-frequency circuits has received little, if any, attention.

The entire behavior of an amplifier or other circuit to applied signals is completely determined by a knowledge of its response to sinusoidal signals in phase and amplitude over the frequency scale. Similarly, its performance is completely determined once its transient response to a so-called unit function, or abruptly steep wave front, is known. It is very likely that similar theorems could be derived for many other functions. The testing method to be chosen depends upon the ease of application and the directness of the information obtained. The waveforms of television images, of speech, and of music are very complicated and

The entire behavior of an amplifier or other circuit to applied signals is completely determined by a knowledge of its response to sinusoidal signals in phase and amplitude over the frequency scale. Similarly, its performance is completely determined once its transient response to a so-called unit function, or abruptly steep wave front, is known. It is very likely that similar theorems could be derived for many other functions. The testing method to be chosen depends upon the ease of application and the directness of the information obtained. The waveforms of television images, of speech, and of music are very complicated and

*Gilbert Swift, "Amplifier Testing by Means of Square Waves," *Communications*, Vol. 19, No. 2, February, 1939.

*A. V. Bedford and G. L. Fredendahl, "Transient Response of Multistage Video-Frequency Amplifiers," *Proc. I.R.E.*, Vol. 25, No. 4, April, 1939.

FIGURE 1. Panel view of the TYPE 769-A Square-Wave Generator.



IET LABS, INC in the GenRad tradition

534 Main Street, Westbury, NY 11590

TEL: (516) 334-5959 • (800) 899-8438 • FAX: (516) 334-5988

www.ietlabs.com

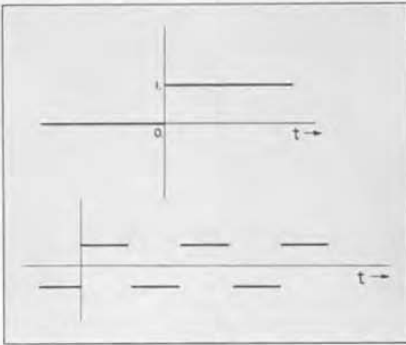

FIGURE 2. At the top is shown a so-called unit function which consists of a suddenly applied voltage. The response of a network to such a signal completely determines the properties of the network. For practical purposes such a transient can be replaced by a square wave of appropriate frequency, like that shown in the lower sketch.

in testing amplifiers it becomes desirable to make use of sinusoidal, square, or other easily reproducible disturbances rather than to use the complicated signals met in practice. Fortunately, the theorems concerning sine waves and unit functions form a good basis for such testing methods.

TELEVISION APPLICATIONS

In television transmitters and receivers it is necessary that the wave

shape of a signal be faithfully reproduced. When large black or white areas are scanned, a long uniform voltage pulse must be passed through a condenser-leak coupling network without having appreciable leakage take place during the cycle. On the other hand, when an abrupt transition from black to white is scanned, it is necessary that the voltage change without appreciable time delay and without an oscillating transient.

Some engineers working on television are of the opinion that square-wave testing is of no great value "except to a service man" because they feel small improvements in a single component of a complicated system can be more readily followed by means of phase and amplitude characteristics than by transients. It is true that in complicated cases cumulative effects are not simply additive in transient response, although in some cases they are approximately additive. Others argue that for television the phase and amplitude curves are so artificial that they are of little use, that one should speak and think in terms of time delays and of "over-shoot ratios" and ignore the rest. Certainly in television the square-wave technique is more direct and gives the answer that is fundamentally required. The phase-amplitude method is difficult to interpret and is at best an intermediate tool of no final significance. Square waves are very easy to use and lead to usable results more rapidly than do other methods.

FIGURE 3. Plot of the voltage across the condenser during charge in the circuit shown below.

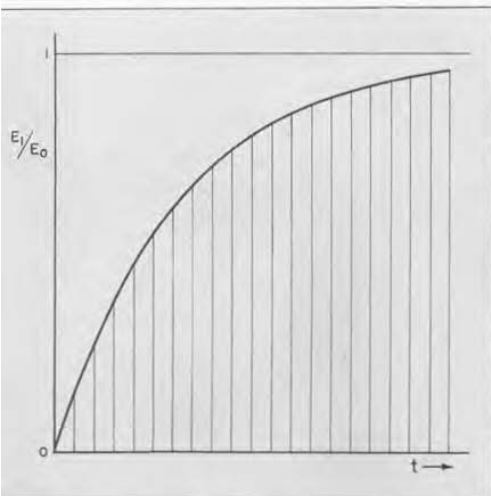
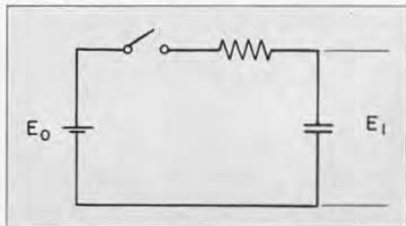

AUDIO-FREQUENCY APPLICATIONS

As is well known, the sounds of music and of speech are usually formed by the interaction of intermittent vibrators (the saw-tooth motion of a violin string, for example) and resonant cavities. The ear distinguishes one sound from another by the wave shape of the quasi-transients set up. One might expect that an amplifier would have to reproduce this waveform accurately in order to lay claim to "high fidelity." Those who are familiar with the strict requirements placed on video amplifiers will realize that acoustic waveforms are certainly not preserved by ordinary audio equipment. For many years, however, it has been the practice to rate the performance of audio equipment on the "frequency characteristic" by which is usually meant the over-all amplitude response as a function of frequency. To be sure, a system which is "flat" from 50 cycles to 10,000 cycles is almost certain to sound better than a system which is only moderately "flat" from 300 to 3000 cycles, but in less obvious examples mere flatness is not necessarily a measure of fidelity. Although little data are on hand, it has been reported that listening tests do not always agree with over-all electrical tests. This is rather to be expected, since the behavior of a network is measured not only by its amplitude response but also by its phase response, and it should not be surprising to find that in some cases the remark, "it sounds terrible" may be more scientific than the statement, "it is flat from 50 to 5000 cycles."

FIGURE 4. Curves of the voltage across a condenser during charge for different values of n , where n is $\frac{1}{2\pi CR}$, which is the ratio of reactance to resistance for the frequency at which the curve shown is the wave shape of the response over a half cycle.

Square waves offer a simple and rapid method of including both phase shift and amplitude response in a single test.

SQUARE-WAVE RESPONSE OF SIMPLE CIRCUITS

Tests made by means of square waves on a wide variety of circuits indicate that the nature of the circuit may be fairly accurately determined without elaborate computation by observation of the transient response. Fortunately, many of the circuits met with in practice give very simple and easily recognized transient response curves, which can be used as a guide for other more complicated cases.

In order to give an idea of this simplicity a single case is treated here. Figure 3 shows the familiar exponential rise of the condenser voltage when a condenser is charged through a resistor. (The curve is drawn for a circuit in which $\frac{1}{2\pi \times 1 \times C} = R$; in other words one in which the condenser reactance at 1 cycle is equal to the resistance.) For other values of the time constant, CR , the resultant curves are exactly the same except for the horizontal scale which is

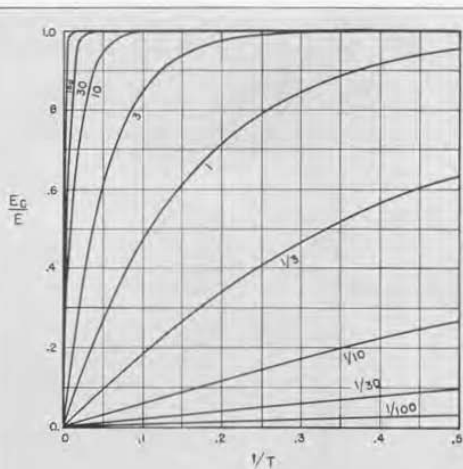

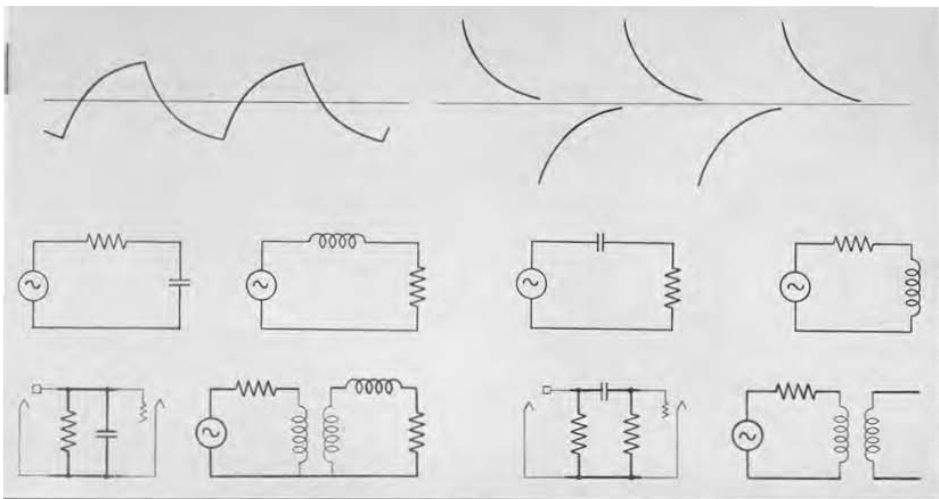

FIGURE 5. The curve at the upper left shows the voltage across the condenser in a series RC circuit when a square wave is applied. Below the plot are shown several circuits giving this type of response. At the right is shown the voltage across the resistor under the same conditions, together with circuits giving a similar square-wave response.

multiplied or divided by a constant factor. Several such curves are shown in Figure 4. If a square wave of unit period is applied to such a circuit the voltage wave across the condenser will be as shown at the left in Figure 5, which is made up of a series of segments each similar to the curve of Figure 3.

The voltage across the resistor is the difference between the applied unit voltage and the condenser voltage. In other words, it is given by the white area above the shaded area of the condenser charge curve. This response is shown at the right in Figure 5.

This same series of curves also applies to the case of inductive circuits where capacity effects are negligible. A group of such circuits is shown in Figure 5 which shows some of the practical cases covered by this one series of curves.

Another article in this month's issue of the *Experimenter* shows the transient curves obtained for a variety of transformers. In a later issue we hope to publish some over-all transient responses for broadcast transmitters and receivers.

In the case of the simple circuits outlined above, it is relatively easy to derive the over-all amplitude-frequency characteristic from the transient response (the converse is not true). In such cases it would seem quite clear that a knowledge of the transient response is more valuable than a knowledge of the amplitude characteristic, because the latter does not necessarily imply a knowledge of the phase response. In very poor, narrow-band, amplifiers it is more difficult to apply square-wave methods because it is difficult to separate the low-frequency cut-off effects from the high-frequency effects. This results in both ends of the characteristic being badly scrambled in a single square wave. In such cases, however, the amplitude response is itself difficult to evaluate in terms of fidelity.

TYPE 769-A SQUARE-WAVE GENERATOR

With this issue the *Experimenter* is announcing a square-wave generator which is primarily intended for audio-

frequency testing. As will be noticed by reference to Figure 7, the circuit consists essentially of an amplifier which is so arranged that it overloads with extraordinary ease. A voltage of 2-8 volts from the power line or an external source is amplified to about 75 volts and it then has both sides of the wave clipped off by a double diode. This squared signal is re-amplified and carefully clipped by a

FIGURE 6. The curves below, left, show the voltage across the condenser in the circuit of Figure 3 when a square wave is applied. Curves (a), (b), and (c) correspond to reactance-to-resistance ratios of 10, 1, and 0.1, respectively. These curves are characteristic of the high-frequency response of fully damped amplifiers. The curves at the right show the voltage across the resistance. Curves (d), (e), and (f) correspond to reactance-to-resistance ratios of 10, 1, and 0.1, respectively. They are characteristic of the low-frequency response of amplifiers.

At the right is shown the amplitude response for a single-stage amplifier. A response of the type of (d) corresponds to a frequency of 1 on this curve, (e) to 10, and (f) to 100. It will be noticed that the amplitude response curve is almost entirely flat at 100, although the response to a square wave of this frequency is by no means square. This illustrates the necessity of considering phase shift as well as amplitude response.

pair of cascaded diodes. Finally, this signal is amplified and attenuated to any desired level.

The generator is not arranged for use at video frequencies but can be used to test the low-frequency response of a video amplifier and is entirely adequate for all audio-frequency use. The internal dynamics of the generator itself are roughly those which would result from an amplifier having a "flat response" from about 1/10 of a cycle to about 250 kc. Complete specifications are given on next page.

The problem of getting quantitative data on the fidelity of amplifiers is a very important one, and it is likely that the customary amplitude rating is insuf-

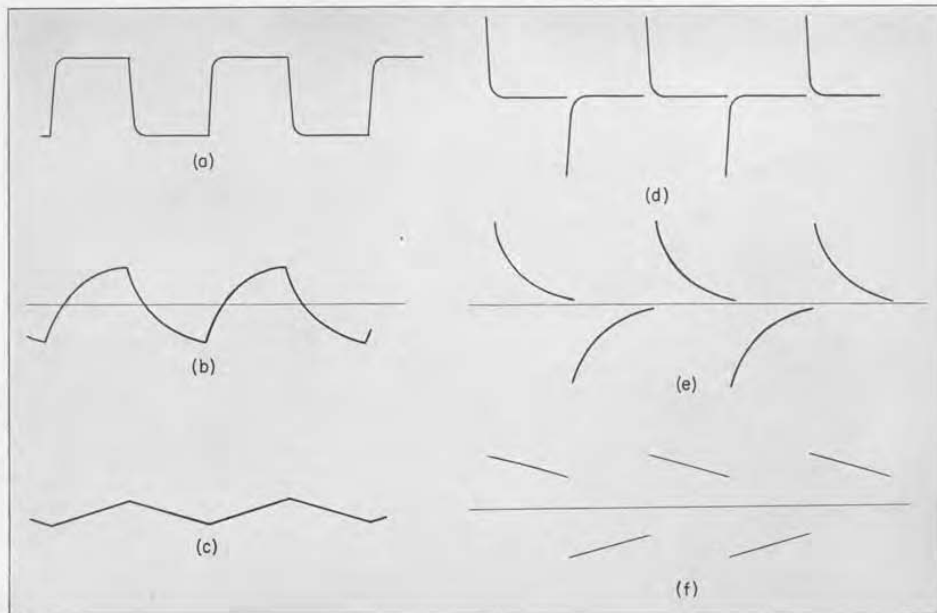
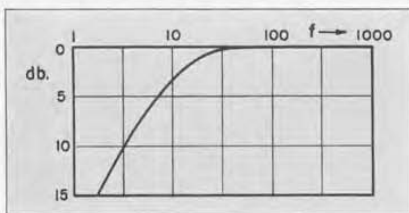

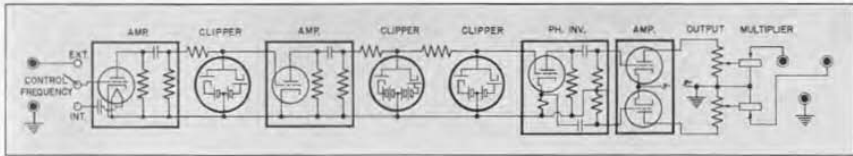

FIGURE 7. Schematic circuit diagram of the TYPE 769-A Square-Wave Generator.

ficient. It would seem highly desirable for someone to make an attempt to correlate transient response with listen-

ing tests. In any case, square waves appear to offer a new possibility of improving high-fidelity performance.

— L. B. ARGUMBAU

SPECIFICATIONS

Frequency Range: Square waves with fundamentals from approximately 10 cycles per second to 5000 can be produced. The output circuit will pass frequencies between 0.1 cycle and 250,000 cycles.

Output Voltage: Peak-to-peak, 150 volts on balanced output; 75 volts unbalanced. The minimum output voltage is 10 microvolts.

Attenuator: A slide wire and a 6-step multiplier are used. The frequency characteristic (wave shape) is not affected by the attenuator setting.

Squareness of Waveform: At low frequencies, the entire rise in voltage takes place in 0.001 cycle.

Output Impedance: 500 Ω, balanced; 250 Ω unbalanced for low-voltage output. The impedance is independent of frequency down to d-c. No condenser is used in the output. B+ is grounded.

External Oscillator: An oscillator capable of delivering 6 volts, open circuit, is required to excite the square-wave generator. A 60-cycle control system is built in.

Power Supply: 105-125 volts, 50-60 cycles. The power input is 60 watts.

Mounting: 19-inch relay-rack panel.

Dimensions: Panel, 19 x 7 inches; depth behind panel, 8½ inches.

Net Weight: 22 pounds.

Type	Code Word	Price
769-A	ASPEN	

HIGH QUALITY AUDIO TRANSFORMERS

● **SQUARE - WAVE TESTING**, the theme of the preceding article in this month's issue of the *Experimenter*, affords an excellent means of reviewing twenty years of audio-transformer history. Figure 1, which shows square-wave patterns for four types of transformers ranging from the early TYPE 231 to the current TYPE 641, is an index of the improvement in the frequency range of reproduced speech and music that has taken place in those twenty years.

Fidelity requirements on audio-frequency systems have constantly in-

creased and, with them, the performance requirements of equipment and circuit components.

The new TYPE 641 Transformers are designed and constructed to meet the exacting requirements of high quality audio systems. Electrically, they have a wide frequency response, they have electrostatic and electromagnetic shields, and accurately balanced windings. Mechanically, they are so designed that the cases can be mounted in several different ways with terminals easily accessible for wiring.



FREQUENCY RESPONSE

Present-day broadcast equipment uses an audio-frequency band of about 30 to 10,000 cycles, sound-recording systems a slightly narrower band. To maintain a flat amplitude response over this range for a whole system requires a far better response of the individual circuit elements.

In an amplifier using three transformers, if each is down 2 db at 10,000 cycles, the over-all response is down 6 db at that frequency, or 2 to 1 in voltage.

Obviously, the transformer characteristic should show no appreciable dropping off at 10,000 cycles. Similar considerations hold for the low-frequency end.

TYPE 641 Transformers are designed for use in high-quality systems, and, for most models, the response is down only 1 db at 20 and 20,000 cycles. Consequently, several units can be cascaded in an audio system without appreciably

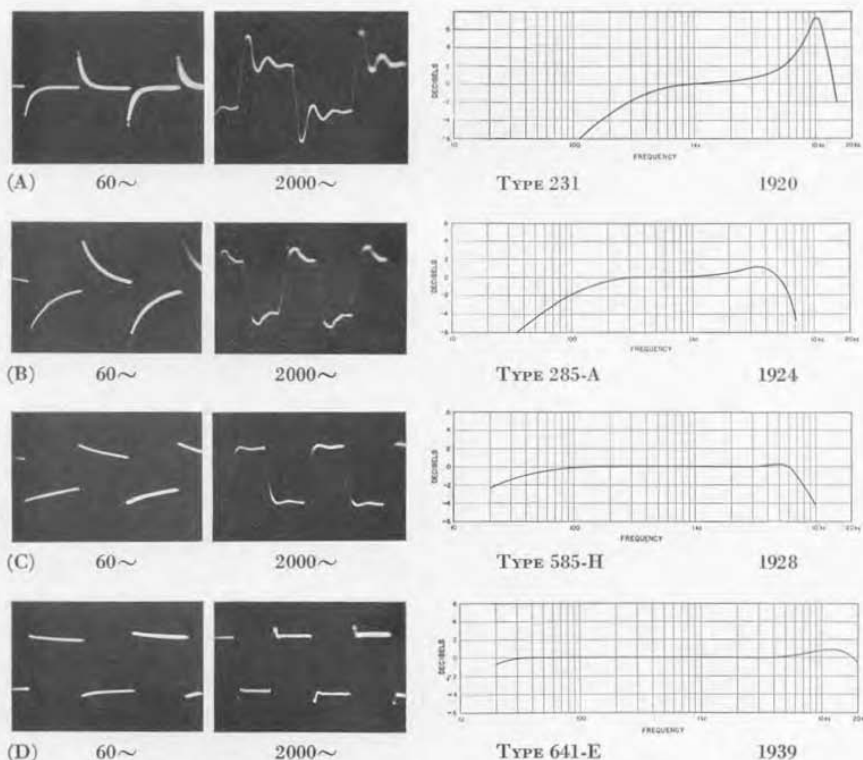

FIGURE 1. Square-wave response patterns and amplitude-frequency characteristics for the transformers indicated in the captions above. The oscillogram at the left is the response to a square wave of 60 cycles fundamental, and the right-hand oscillogram is for a wave of 2000 cycles fundamental. These oscillograms should be compared with the curves on page 5. The 60-cycle response shown above is similar to curves (d), (e), and (f) on page 5. The 2-kilocycle pattern is basically the same as that of curve (a), but there is superposed on the curve a damped oscillation of a frequency corresponding to that of the resonant point in the amplitude-frequency curve. This transient could be suppressed by increasing the secondary damping.

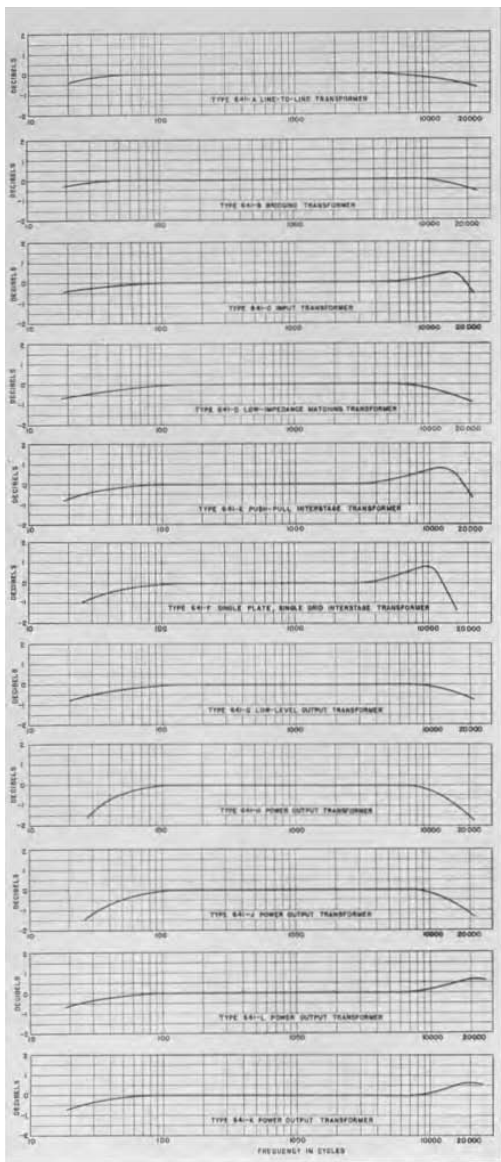

FIGURE 2. Typical amplitude-frequency curves for all models of TYPE 641 Transformer.

affecting the frequency characteristic. Of equal importance is the transient response of the transformer as measured by an applied square wave. As the oscillogram of Figure 1 shows, very little distortion of the square wave occurs in TYPE 641 units.

Frequency response curves for all models are shown in Figure 2. Since the apparent low-frequency response of a transformer can be varied by a number of factors, such curves are of little value unless the conditions under which the measurements are made are completely stated. Two things are important with regard to the curves shown here:

(1) The low-frequency response data are taken, not under the most favorable conditions, but under the *least* favorable ones.

(2) The measurements are accurate.

A characteristic of high permeability alloy cores is that the permeability at very low levels is considerably below the maximum value. Tests on the output models are made with 0.1 volt applied to the primary; normal operating level is, of course, much higher. In order to assure accurate measurements at low levels, the low-frequency response is measured with a TYPE 736-A Wave Analyzer. This also eliminates all errors caused by hum and by harmonics in the test oscillator. The general method of measurement has been covered in a previous article.* It can be seen from the curves of Figure 2 that the response at 20 cycles for many of these transformers is down less than 1 db, necessitating an accuracy of measurement of about .2 db or 2%. Without the wave analyzer, using a good beat-frequency oscillator and a vacuum-tube voltmeter, the error at 20 cycles may be considerably greater than this, both because of oscillator harmonics and because of waveform error in the voltmeter. When the wave analyzer is used, the waveform of the oscillator is unimportant.

CONSTRUCTION

Careful design and construction account for many of the excellent charac-

*A. E. Thiessen, "Waveform Errors in the Measurement of Filter Characteristics," *General Radio Experimenter*, March, 1935.

teristics of these transformers. The core is made up of thin laminations of high-permeability alloy. Windings are in two symmetrical sections to assure accurate balance to ground. An electrostatic shield between primary and secondary isolates the two circuits so that the transformer can be used between a grounded circuit and a balanced circuit.

Low-loss insulating material tested on 1000 volts is used between windings and between winding and core. Coils are wound in layers insulated from one another with less danger of breakdown and shorted turns than occurs in random-wound coils. Input, interstage models and impedance-matching, which operate usually at low levels, are provided with a high-permeability magnetic shield which attenuates a-c hum by about 50 decibels. Outside the magnetic shield is the aluminum case. Terminals are brought out at one end.

BALANCE

Excellent shielding and balance-to-ground is obtained in these transformers.

FIGURE 3. (a) Circuit for measuring longitudinal transmission; (b) circuit for measuring longitudinal and unbalance transmission.

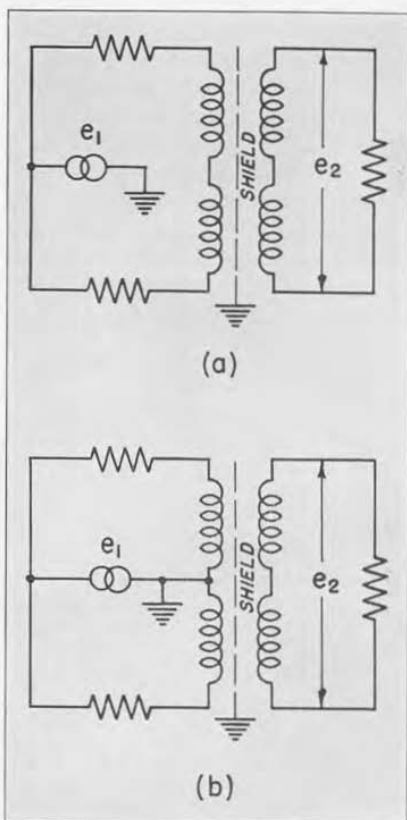
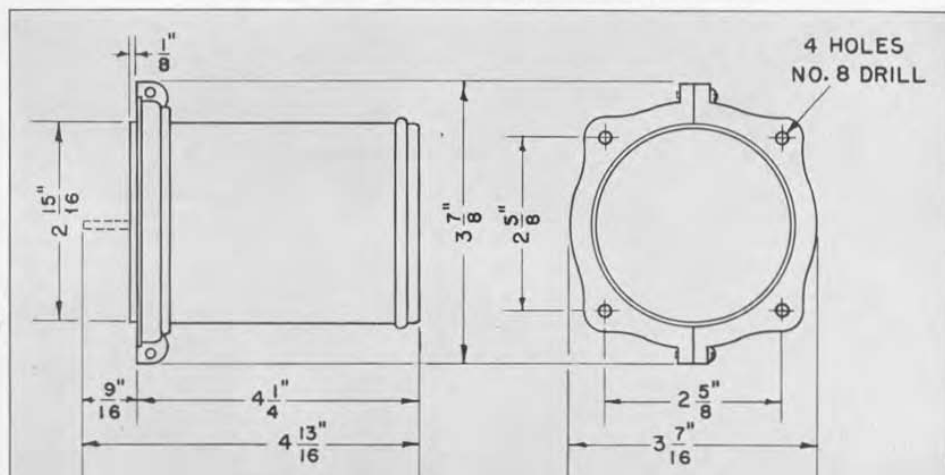

FIGURE 4. Over-all dimensions of TYPE 64I Transformer.



For the types used in broadcasting and sound-recording service, the balance is sufficiently good to balance out all pick-up from hum or other sources on the lines to which they are connected. Figures for longitudinal and unbalance transmission for these models are given below.

The so-called longitudinal transmission, measured as indicated in Figure 3a, is a measure of the electrostatic shielding. By introducing e_1 as shown in Fig-

ure 3b, the sum of unbalance and longitudinal transmission is obtained.

MOUNTING

Not least among the features of these transformers is the method of mounting. The case is clamped in a metal ring, which is in turn attached to baseboard or shelf on which the transformer is to be mounted. The case can be mounted either above or below the shelf, with terminals projecting in either direction. Figure 5 tells the story completely.

— L. E. PACKARD

SPECIFICATIONS

Type	Longitudinal and Unbalance Transmission (Decibels Below Test Voltage)*			Longitudinal Transmission (Decibels Below Test Voltage)*		
	100 ~	1 ke	10 ke	100 ~	1 ke	10 ke
641-A	72	55	40	95	105	81
641-B	87	58	47	85	79	61
641-C	68	39	17	85	65	57

*One volt applied as shown in Figure 3.

Uses: See table. Numbers refer to the more common types of tubes with which the model can be used.

Frequency Range: The table gives the frequency range over which the voltage ratio is less than 1 decibel below its value on the flat portion of the characteristic, and the operating conditions for this performance. Sample frequency curves are given in FIGURE 2.

The frequency range naturally holds only when the primary source has an internal impedance equal to that specified under "Out of (ohms)," and the load is as specified under "Into (ohms)." In several of the output transformers the source impedance from which they are to work is different from the impedance which should be reflected back to the tube by the transformer. The table gives the proper source impedance (the plate resistance of the tubes), while the footnotes give the load impedance as seen by the tube.

The column headed "Pri. DC" gives the maximum direct current which can be handled by each section of the primary winding under

balanced conditions, while the "Unbalance DC" column gives the maximum allowable current unbalance for the stated frequency range, and the allowable direct current when the unit is operated single-ended.

Maximum Level: Under the column "Max. Level" is given the audio power or primary voltage which each transformer will handle with negligible distortion. At higher values some low frequency distortion occurs.

Turns Ratio: The ratio of turns of the whole primary winding to the whole secondary winding is given in the "Turns Ratio" column.

Electrostatic Shielding: The line-to-line, bridging, input, and low-impedance matching transformers, TYPES 641-A, -B, -C, and -D, respectively, all have an electrostatic shield to assure isolation between the primary and secondary windings.

Magnetic Shielding: The line-to-line, bridging, input, low-impedance matching, and inter-stage transformers, TYPES 641-A, -B, -C, -D,

FIGURE 5. Several ways of mounting TYPE 641 Transformers. From left to right: above shelf with terminals at top, above shelf with terminals below, below shelf with terminals at top (clamping ring can be below shelf, if desired), and below shelf with terminals at bottom.



-E, and -F, respectively, all have a high permeability magnetic shield which introduces about 50 decibels of attenuation to hum pickup.

Terminals: Soldering lugs are provided.

Mounting: Each transformer is mounted in a cylindrical aluminum case. The base clamps on and is arranged so that the unit can be mounted

above or below the mounting shelf with the terminals either up or down.

Dimensions: See FIGURE 4.

Net Weight: 3 pounds, all types.

Type	Uses	Out of ¹ (ohms)	Into ¹ (ohms)	Pri. DC balance (bal) (ma)	Un- DC (ma)	Freq. Range Down 1 db		Max. Level	Turns Ratio	Code Word	Price
						From (cycles)	To (cycles)				
641-A	Line, Mixer to Line, Mixer ^{5a}	50 to 60 125 to 150 200 to 240 500 to 600	50 to 60 125 to 150 200 to 240 500 to 600	—	—	20	20,000	6 watts	1 to 1	UDDER	
641-B	Bridging 500 to 600Ω Lines ^{5a}	10 to 1000 ²	50 to 60 125 to 150 200 to 240 500 to 600	—	—	20	20,000	20 watts in line	4.1 to 1	ULCER	
641-C	Line, Mixer ^{5a} to P-P or Single Grids	50 to 60 125 to 150 200 to 240 500 to 600	P-P Grids or Single Grid (Class A)	—	—	20	20,000	30 volts across total primary	1 to 8.9	UMBER	
641-D	Low-Impedance Matching ^{5a}	1.2, 2.5, 5, 7.5, 10, 15, 20, 30	50 to 60 125 to 150 200 to 240 500 to 600	—	—	20	20,000	6 watts	1 to 4.1	UNDER	
641-E	P-P Plates (6C5, 6J5, 6L5-G, etc.) to P-P Grids	16,000 to 24,000 plate-to-plate	P-P Grids	40	—	20	20,000	120 volts, plate-to-plate	1 to 2.1	UNION	
641-F	Single Plate (6C5, etc.) to Single Grid	9000 to 13,000	Single Grid (Class A)	—	10	30	14,000	70 volts across primary	1 to 3	UNITY	
641-G	P-P Plates (6C5, 6J5, etc.) to Line ⁵	10,000 to 40,000	50 to 60 125 to 150 200 to 240 500 to 600	40	—	20	20,000	6 watts	6.3 to 1	UNCLE	
641-H	P-P or Single Plates (2A3, 6A3, 45, etc.) to Speaker	800 to 2200 ⁷	1.2, 2.5, 5, 7.5, 10, 15, 20, 30	95	60	30 ³	20,000 ³	20 watts	12.9 to 1	VIZOR	
641-J	P-P or Single Plates (2A3, 6A3, etc.) to Line	800 to 2200 ⁷	50 to 60 125 to 150 200 to 240 500 to 600	95	60	30 ³	20,000 ³	20 watts	3.1 to 1	VOCAL	
641-K	P-P Plates (6L6, etc.) to Speaker	20,000 to 40,000 ⁴	1.2, 2.5, 5, 7.5, 10, 15, 20, 30	90	5	20	20,000	20 watts	14.3 to 1	WEARY	
641-L	P-P Plates (6L6, etc.) to Line ⁵	20,000 to 40,000 ⁴	50 to 60 125 to 150 200 to 240 500 to 600	90	5	20	20,000	20 watts	3.5 to 1	WINDY	

¹These limits may be changed by as much as 10% without causing appreciable changes in the transformer characteristics. This transformer places a load of 5000 or 20,000 ohms across the line, depending on which tap is used. To do this and still match output impedances, series resistors are built into the unit.

²Response is down 2 db at these frequencies except on 2.5 Ω and 10 Ω taps of TYPE 641-H where response is down 2 db at 14,000.

³This transformer places a load of 6000 ohms across the tubes. This is the proper load for 6L6's operating CLASS A or AB.

⁴240 Ω and 600 Ω taps can be used either balanced or single-ended.

⁵These transformers have electrostatic shielding between windings.

⁷This transformer places a load of either 3000 or 5000 ohms across the tubes. These are the proper loads for 2A3's operating with fixed or self-bias respectively.



MISCELLANY

● **AN EXHIBIT** of General Radio apparatus will be held at the Stevens Hotel, Chicago, from February 12 to 17, 1940. This is to be a working display of equipment as it is used in typical applications and will include many new instruments. *Experimenter* readers are cordially invited to attend.

● **"ENGINEERING ADMINISTRATION** in a Small Manufacturing Company" was the title of a paper delivered by C. T. Burke at I.R.E. Convention, New York, September 20; at the Philadelphia Section, I.R.E., on November 2, and at the Emporium (Pennsylvania) Section, November 10.

● **DESIGNERS** of the instruments described in this issue:

TYPE 769-A Square-Wave Generator, L. B. Arguimbau; TYPE 641 Transformers, L. E. Packard.

● **AT THE ROCHESTER** Fall Meeting of the I.R.E. and R.M.A., E. Karplus delivered a paper on "Standard-Signal Generators" and L. B. Arguimbau spoke on "Square-Wave Testing," accompanying his talk with a demonstration. At the banquet, H. B. Richmond, treasurer of the General Radio Company, spoke on the subject of co-operation between the I.R.E. and R.M.A.

THE General Radio EXPERIMENTER is mailed without charge each month to engineers, scientists, technicians, and others interested in communication-frequency measurement and control problems. When sending requests for subscriptions and address-change notices, please supply the following information: name, company name, company address, type of business company is engaged in, and title or position of individual.

GENERAL RADIO COMPANY

30 STATE STREET - CAMBRIDGE A, MASSACHUSETTS

BRANCH ENGINEERING OFFICES

90 WEST STREET, NEW YORK CITY

1000 NORTH SEWARD STREET, LOS ANGELES, CALIFORNIA

